

X Out of Box Audit Precautions

Upon your receiving of the ordered product, unpack and inspect it as below :

- Check whether the appearance has been damaged during the transportation, such as shell or glass ;
- Check whether there is the operating manual for this product and other operating manuals, certificates of quality, product drawings, etc.

XI Order Information

- In model selection, specify the specification and installation method, and the model of desired product according to the meanings of the total unit and subunits ;

Note:

Read this manual carefully before the use. Renewal and upgrade of some products will not be notified separately. The right to interpret the product is owned by the company.

Manufacturing base: Guodong Wuxing Industrial Park, Dainan Town, Xinghua City, Jiangsu Province

Tel:+86 83769832

Fax:+86 83769550

Company website:www.santothermal.com

Postal code:225700



Operating Manual

HDBK-WK Series Intelligent Explosion-Proof Temperature Controller



圣拓热控科技江苏有限公司
Santo Thermal Control Technology Co., Ltd

! Safety Precautions

- ◆ This product must be installed and maintained by professionals ;
- ◆ This product can only be used within its specified range ;
- ◆ Any violation of the service regulations will nullify the warranty we provide ;
- ◆ Any practice aiming to change, neglect or weaken the product's performance is not permitted. We shall not be liable for any consequence arising therefrom ;
- ◆ Installation, operation, and maintenance must comply with the following regulations :
 - ★ National security requirements ;
 - ★ Installation regulations in countries concerned, such as Chinese National Standard Gb3836. 15, IEC60079- 1etc ;
 - ★ Generally recognized technical regulations ;
 - ★ Safety requirements in the operating manual ;
 - ★ In case of failure, repair of the product should be entrusted to professionals.

! Test run

- ◆ Installation of the product has been finished correctly as required;
- ◆ Wires are connected properly, and the product is effectively grounded;
- ◆ Unused cable inlets and outlets have been effectively blocked off;
- ◆ All the seals produce a sealing effect;
- ◆ All parts are installed or replaced. No damaged ones; All parts are installed at right installation sites; No mechanism has jam; All indicators work properly;

! Proper usage

- ◆ Read this operating manual carefully before installation, operation, and maintenance ;
- ◆ When working in a danger zone, personal safety and device safety depend on whether relevant safety requirements concerning the product have been satisfied ;
- ◆ The personnel responsible for installation, operation and maintenance shall possess knowledge of relevant practical standards and regulations.

IX Dimensions, Installation Examples, Working Principle and Schematic Diagram

Schematic Diagram

Figure1

Input working voltage AC380V
Three-phase five-Wire 3P+N+PE

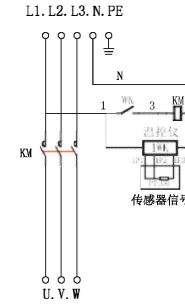

Figure1

Figure2

Input working voltage AC220V
Single-phase 1P+N+PE

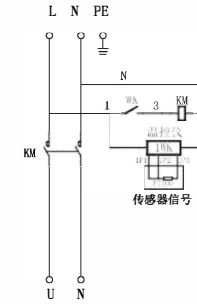
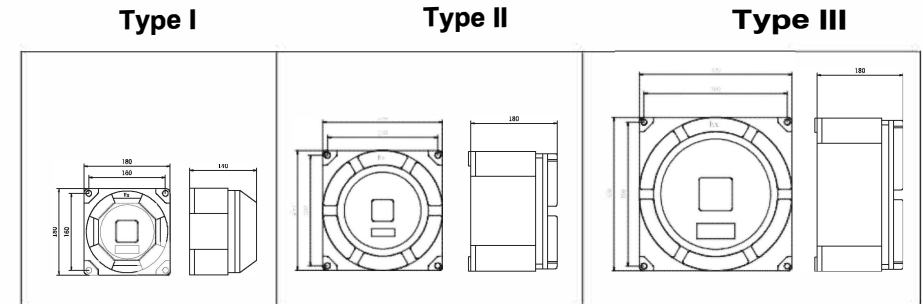

Figure2

Note: This working principle diagram is for the conventional type product. For more functions, contact with the manufacturer. .

External dimensional drawings



Mounting bracket unit(mm)

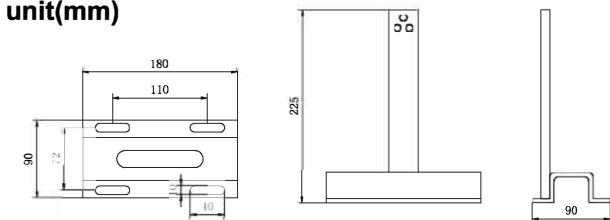



VIII Instructions on the Intelligent Temperature Controller

Descriptions of Panel Display

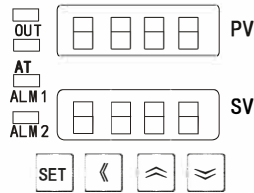

- (1) PV : In a normal display situation, it indicates the measured temperature; and in a parameter setting, it displays the parameter symbol.
- (2) SV: In a normal display situation, it indicates the set value of temperature; and in a parameter setting, it displays the parameter value.
- (3) ALM1: When this indicator light is on, ALM1 relay of the instrument has output.
- (4) ALM2: When this indicator light is on, ALM2 relay of the instrument has output.
- (5) AT: When the instrument auto-tunes itself, this indicator light is on.
- (6) OUT: When this indicator light is on, the OUT control terminal of the instrument has output.
- (7)Function key(SET):Press this key for 3 seconds, the parameter modification status is entered.
- (8) Shift key (◀): During the parameter modification, press this key, the position of altered will be shifted;press it for 3 seconds, one can enter or exit from the manual adjustment.
- (9) Value decrease key: During the parameter modification, set value modification or manual adjustment,pressing this key can decrease the value.
- (10) Value increase key: During the parameter modification, set value modification or manual adjustment, this key can increase the value. Press it for 3 seconds, the set value modification state will be entered.

Operating Menu

Parameter setting

After powering up the product, press SET key for about 3 seconds, the instrument enters the first setting area. Then parameter symbols will be displayed in the upper display window and the corresponding parameter values in the lower display window in the order of parameter code. At this moment, the parameter value can be adjusted by pressing one of the three keys, SET, ↑ and ↓. Long press ↑ or ↓, the decrease or increase can be accelerated. After the adjustment of one parameter, press SET key to confirm and save the data. Then switch to the next one till the adjustment is finished. To exit quickly, long press SET key; to exit directly, press SET+.

Press SET key for 5 seconds and find the temperature difference setting. The difference value can be set according to the operating requirements. For example, when the set temperature is 40°C and the temperature is controlled within the range of 30°C ~50°C, the temperature difference value is set 20°C. The rest can be done in the same manner.

Factory settings:

Set temperature Sv is 40°C,
 Range of temperature control is 35°C~45°C,
 Input type PT100/100(-200~650°C),
 Control return difference is 10°C,
 Inlet wire of sensor is a three-wire system,
 If the wiring of the on-site customer is a two-wire system, two wires among the three can be connected in parallel.

For detailed instrument parameters, contact the manufacturer.

Introduction

With the rapid development of the chemical industries, such as petrochemical industry, natural gas industry, and power generation industry, and the extensive application of new generation energy-saving electrical heating products, our company has developed an intelligent explosion-proof temperature controller. This product is mainly used for the terminal temperature control in electric tracing in lieu of a mechanical temperature controller. Compared with the mechanical temperature controller who has one single function of power supply control, this product has optimized performance and accuracy, and functions such as current protection, current limiting, warning about phase loss, overcurrent, electric leakage and failure, and monitoring and communication.

I Scope of Application and Usage

- Applicable to Zone 1 and Zone 2 areas in explosive gas atmospheres ;
- Applicable to IIA and IIB explosive gas atmospheres;
- Applicable to combustible dust Zones 21 and Zone 22;
- Applicable to temperature groups T1~T6 ;
- Widely used in hazardous atmospheres including oil exploitation, oil refining, chemical engineering, pharmaceutical engineering and war industry, offshore oil platforms, oil tankers and other sites ;
- This product is mainly used for the purpose of power supply control in electrical heating or electric tracing.

II Environmental Service Conditions

- The altitude of installation site shall not exceed 2000m ;
- Operating ambient temperature is usually within the range of -20°C~ +40°C ;
- Relative humidity in the ambient air is not higher than 95%<+25> ;
- Class of pollution: Class 3 ;
- Installation category: Categories I and II.

III Model Meaning

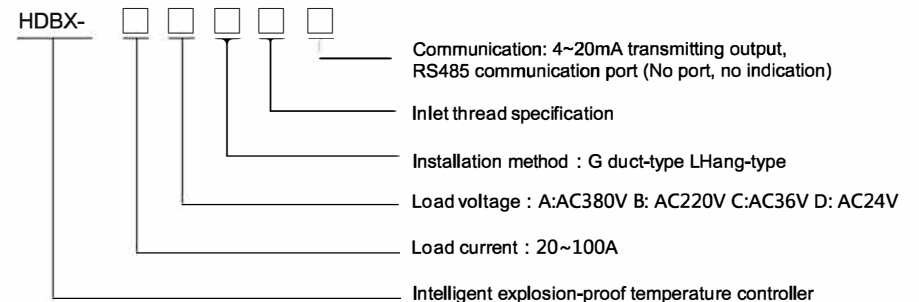



IV Features

- The shell is cast and formed by the aluminum alloy, is welded with SS304/316 stainless steel and contains engineering plastics ;
- The controller is mainly composed of a digital intelligent temperature controller, an AC contactor, signal lights, RCD, terminals, etc;
- Different current ranging from 10A to 100A can be customized according to customers' requirements;
- The one-piece design provides bigger wiring space and a reasonable layout;
- Amphenol connectors adopted are made of compressed pure copper, which enhances the safety of the product;
- The intelligent temperature controller has multiple functions for the user to choose from, and further function can be customized as required;
- This product adopts the whole explosive-proof form, has reliable explosive-proof performance, and is applicable to dust explosion areas;
- Its cover and body are equipped with a hinge, making the installation and servicing easy and fast;
- The product has a good protection performance and can be directly used outdoors;
- Cable wiring.,

V Technical Parameters

Executive standards : GB3836.1、GB3836.2、GB12476.1、IEC60079-0、IEC60079-1、IEC61241-1、EN60079-0、EN60079-1、EN61241-1
 Ex-Mark : Exd IIBT6Gb、Exd IICT6Gb、Ex tD A20IP65T80°C、II2GExd IICT6Gb、II2Extb IICT80°C Db IP65
 Rated voltage: AC380V, AC220V, AC36 V, AC24V(Specify special requirements, if any)
 Rated current : 20A~100A
 Communication function : 4~20Ma transmitting output, RS485 communication port, etc
 Protection level : IP65
 Corrosion-proof grade : WF1 *WF 2
 In-built components: Temperature controller, AC contactor, indicator lights, switches, current limiter change-over switch, etc
 Inlet thread: G1/2"~G2 intake specification (Specify special requirements, if any)
 Outer diameter of cable: Suitable for Φ12mm~Φ80mm cables
 Installation methods: Hang-type, duct-type and floor-type

VI Product Selection

Type specification	Rated voltage	Rated current (A)	Power inlet-outlet thread	Sensor outlet thread	External dimensions (mm)	Enclosure code
HDBX-WK-20	AC380V AC220V AC36V AC24V	20	G1/2"	G1/2"	180*180*140	I
HDBX-WK-25		25	G3/4"	G1/2"	180*180*140	I
HDBX-WK-40		40	G1"	G1/2"	180*180*140	I
HDBX-WK-60		60	G1 1/4"	G1/2"	250*250*180	II
HDBX-WK-100		100	G2"	G1/2"	320*320*180	III

VII Installation, Use, and Maintenance

- Before installation, check whether the basic data specified on the product label fit the actual service conditions ;
- In the installation, cables or wires are introduced into the shell or the wiring cavity through the lead-in device, and then the rubber seal ring is impacted with a steel pipe, metal gland nuts or explosion proof cable seal joints to the extent that the cable is sealed. During this process, it should be noted that the outer diameter of cable should match with the used lead-in device. If wires go through the steel pipe, anti-explosion isolation sealing pipe joints need to be installed in accordance with relevant national standards and regulations. If the wires are introduced directly, anti-explosion cable-clamped seal joints bearing relevant explosion-proof signs should be installed in accordance with Chinese national standard GB3836.15-2000. Unused inlets and outlets of the cable lead-in device must be effectively sealed ;
- Check whether the switches, the operating mechanism and the restoration of control buttons are flexible and reliable and whether the breaking is in place ;
- Before use, check whether all parts of the product have been installed correctly and the breaking is in place ;
- The product must be grounded both internally and externally ;
- It is strictly prohibited to open the electrified cover to ensure the operator's safety and the site safety ;
- During installation and maintenance, disconnect the power supply at the preceding stage before uncovering. After uncovering, check whether all parts are intact, and replace the damaged ones timely, if any ;
- During installation and maintenance, the flameproof joint must be free of knock, collision, and scratches and coated with 204-1 rust-preventive oil. After the maintenance is finished, tighten all the fastening screws ;
- During installation and maintenance, it should be guaranteed that the electric clearance in the wiring cavity is no less than 6mm and the creepage distance no less than 12.5mm ;
- If aging of rubber sealing gaskets is found during the maintenance, contact our company for replacement for fear that it influences the product's anti-explosion and protection performance ;
- In maintenance, pay attention to the selection of material when replacing metal pieces to guarantee the product's antiseptic property ;
- To guarantee the normal operation of the product, the user must conduct an inspection regularly in accordance with the following provisions ;
 - 1 Visual inspection and cleaning work. If the metal shell and parts are peeling or there are rusts on the surface, use an abrasive cloth to polish the surface and then coat it with antirust paint ;
 - 2 Check whether the electrical performance of the product is in good condition ;
 - 3 The user is recommended to maintain the product every six months and have it serviced once a year.